

Operator's Manual

ET1187 Crimp Machine

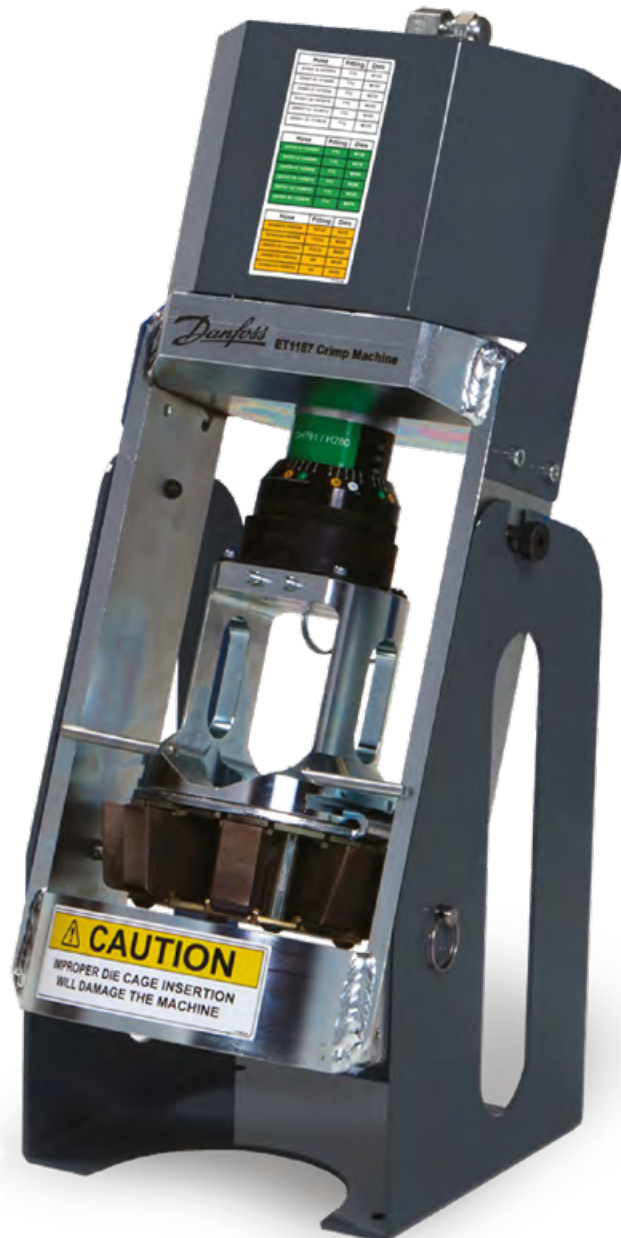

Table of contents

Section	Page
Safety Instructions	2
Specifications	3
Accessories	3
Set-up and Assembly	3
Operating Instructions	4
Maintenance	7
Description of Components	8
Contact Information	10

Safety instructions

Read and understand the operator's manual before attempting to operate any equipment.

WARNING

Aeroquip hose, hose fittings and assembly equipment should be used only with other Aeroquip hose, hose fittings and assembly equipment and Weatherhead hose, hose fittings and assembly equipment should be used only with Weatherhead hose, hose fittings and assembly equipment. Do not combine or use Aeroquip or Weatherhead hose, hose fittings and assembly equipment with each other, i.e. Aeroquip hose with Weatherhead fittings, or with hose, hose fittings or assembly equipment supplied by another manufacturer.

Danfoss hereby disclaims any obligation or liability (including incidental and consequential damages) arising from breach of contract, warranty, or tort (under negligence or strict liability theories) should Aeroquip or Weatherhead hose fittings or assembly equipment be used interchangeably or with any hose, fittings or assembly equipment supplied by another manufacturer, or in the event that product instructions for each specified hose assembly are not followed.

WARNING

Failure to follow process and product instructions and limitations could lead to premature hose assembly failures, resulting in property damage, serious injury or death. Aeroquip and Weatherhead fitting tolerances are engineered to match Aeroquip and Weatherhead hose tol-

erances. The combination or use of Aeroquip or Weatherhead hose and hose fittings with each other, i.e. Aeroquip hose with Weatherhead fittings, or with hose or fittings supplied by another manufacturer may result in the production of unreliable and/or unsafe hose assemblies and is neither recommended or authorized by Danfoss.

Safety Instructions

- 1. PREVENT UNAUTHORIZED OPERATION.** Do not permit anyone to operate this equipment unless they have read and thoroughly understand this manual.
- 2. WEAR SAFETY GLASSES.**
- 3. AVOID PINCH POINTS.** Do not rest your hand on the crimp ring. Keep your hands clear of all moving parts. Do not allow anyone, other than the operator, close to the equipment while it is in operation.
- 4. MAINTAIN DIES WITH CARE.** Dies used in the ET1187 crimp machine are hardened steel, offering the best combination of strength and wear resistance for long life. Hardened dies are generally brittle and care should be taken to avoid any sharp impact. Never strike a die with a hardened instrument.
- 5. USE ONLY SPECIFIED AEROQUIP/ WEATHERHEAD PRODUCTS.** Make hose assemblies using only Aeroquip and Weatherhead hose and fittings specified for this assembly equipment.

- 6. VERIFY CORRECT CRIMP DIAMETERS.** Check and verify correct crimp diameters of all fittings after crimping. Do not put any hose assemblies into service if the crimp diameters do not meet Danfoss crimp specifications.
- 7. Make sure all dies are completely in place,** the spacer ring rests against the placement pins, and the pusher is pulled forward into the detent position before crimping.
- 8. DO NOT OVER PRESSURIZE.** Do not exceed the 10,000 psi hydraulic pressure supplied to the machine.
NOTE: All components used to connect the pump and crimp cylinder must meet the criteria set forth in the Material Handling Institute Specification #IJ100 for hydraulic jacking applications.
- 9. DIE CHANGE. DO NOT INSERT/REMOVE DIES WHILE THE POWER IS ON OR MACHINE IS IN OPERATION.**
- 10. SECURE THE EQUIPMENT TO A STABLE WORK SURFACE.** Prior to operation, secure the crimp machine to a stable work surface to prevent the equipment from tipping.
- 11. UNPLUG THE POWER SUPPLY WHEN NOT IN USE.**
- 12. KEEP WORK AREA CLEAN.** Cluttered areas and benches invite accidents.

Specifications and Accessories

TECHNICAL DATA



ET1187-001
(Bench Mount)



ET1187-002
(Truck Mount)

NOTE

Your new crimp machine has been calibrated and filled with hydraulic oil in the factory. Do not remove any plugs or caps until necessary. Excess air in the hydraulic system may cause erratic cylinder movement during retraction.

SPECIFICATIONS

Dimensions – 22" High x 9" Wide x 11" Deep
Weight – 65 lbs

CRIMP MACHINE PART NUMBERS

ET1187-001 = Bench Mount Machine, no pump, no tooling (includes bracket) - for premium hose GH681/H180, GH781/H280, GH493/H430

ET1187-002 = Truck Mount Machine, no pump, no tooling (includes bracket) - for premium hose GH681/H180, GH781/H280, GH493/H430

ET1187-003 = Bench Mount Machine, no pump, no tooling (includes bracket) - for Winner hose EC115, EC215, EC118

ET1187-004 = Truck Mount Machine, no pump, no tooling (includes bracket) - for Winner hose EC115, EC215, EC118

ET1187-008 - Crimper package contains ET1187-001 crimp machine, 110 volt electric pump kit, and the ET4020TP-0002 tooling package

ET1187-010 - Crimper and saw package contains ET1187-001 crimp machine, 110 volt electric pump kit, the ET4020TP-0002 tooling package, the ET9000-45-110 portable saw, and the ET1187C-0029 portability kit

CRIMP DIES

ET4020TP-0002 – Die Package for -4, -6, -8, -12, -16 Braided and -6, -8, -10, -12 Spiral (Includes M150, M180, M210, M240, M280, M320, M370 Dies)

ET4020TP-0003 – Die Package for -4, -6, -8, -12, -16, -20 Braided and -6, -8, -10, -12, -16 Spiral (Includes M150, M180, M210, M240, M280, M320, M370, M420, and M465 Dies)

FT1380-200-M420 – Die for -16 Spiral

FT1382-200-M465 – Die for -20 Braided

PUMP PART NUMBERS*

ET1000PK-001 = 2-Stage Hand Pump

ET1000PK-002 = Air/Hydraulic Pump

ET1000PK-003 = 110 Volt Electric Pump

ET1000PK-004 = 12 Volt DC Electric Pump

* These pump kits include the pump, connecting hose assembly, and all of the adapters necessary to connect the pump to the ET1187 crimp machine.

ACCESSORY PART NUMBERS

T-400-G = 1.5 oz. Tube, High Efficiency PTFE Grease

FF91455 = 16 oz. Can, High Efficiency PTFE Grease

ET1187C-0008PR - Replacement barrel for the ET1187-001, ET1187-002 (for premium hose GH681/H180, GH781/H280, GH493/H430)

ET1187C-0008WR - Replacement barrel for the ET1187-003, ET1187-004 (for Winner hose EC115, EC215, EC118)

ET1187C-0009PR - Replacement knob for the ET1187-001, ET1187-002 (for premium hose GH681/H180, GH781/H280, GH493/H430)

ET1187C-0009WR - Replacement knob for the ET1187-003, ET1187-004 (for Winner hose EC115, EC215, EC118)

ET1187C-0017 = Bench Mount Bracket

ET1187C-0019 = Truck Mount Bracket

ET1187C-0028 - Optional handle kit with 2 easy grip handles and mounting hardware

ET1187C-0029 - Portability kit including handle kit, longer hose assembly, and FF series QD couplings

ACCESSORIES



Bench Mount Stand.
(Part number: ET1187C-0017).



Wall Mount Bracket.
(Part number: ET1187C-0019).



High Performance PTFE Lubricant
(Part # T-400-G)

ET1187 Crimp Machine Operator's Manual

Die Cage Part Number	1 Wire Braid 1A (TTC)/Z/Winner	2 Wire Braid 1A (TTC)/Z/Winner	Spiral Hose 4S Fitting	ET4020TP-0002	ET4020TP-0003
FT1380-200-M150	-4	-4		×	×
FT1380-200-M180	-6	-4 [†]		×	×
FT1380-200-M210	-8	-6	-6	×	×
FT1380-200-M240	-10	-8	-8 ^{††}	×	×
FT1381-200-M280	-12	-10, -12 [†]	-8, -10	×	×
FT1380-200-M320		-12	-12	×	×
FT1380-200-M370	-16	-16		×	×
FT1380-200-M420			-16		×
FT1382-200-M465	-20	-20			×

† - Die cage used to crimp Winner Hose with Two Piece Winner Fitting

†† - Die cage used to crimp Winner Hose with 4S Fitting

Note: Additional dies and die cages also available. Refer to website or contact Danfoss.

Setup and Assembly

- 1.** Your new ET1187 crimp machine comes assembled for ease of shipment. Before use, the machine must be assembled to the base with the supplied quick release pins.
- 2.** Remove the cap from the top cylinder port and install the -06 size ORS, 90 degree adapter using 23-24 ft. lbs. assembly torque. Orient the adapter so that it points to the rear of the crimp machine, away from the operator.
- 3.** Install the pump connecting hose assembly to the cylinder adapter with the -06 size 37 degree swivel nut fittings using 18-20 ft. lbs. assembly torque.
- 4.** Do not exceed an 8" minimum bend radius of the pump connecting hose when attaching the hose to the pump and cylinder.
- 5.** If using your own pump, make sure it has the requirements listed in the specifications section above.
- 6.** Place the pump on the work surface to either side of the crimp machine. Install the 90 degree adapter to the pump pressure port (Male NPTF threads should be tightened following the hex-marking procedure of 2 to 3 turns past hand tight).
- 7.** Remove excess air from the hydraulic system. This can be accomplished by placing the pump at a higher level than the cylinder and cycling the machine approximately five times.
- 8.** Secure the machine frame to a stable work surface using lag screws or other suitable fasteners.

Operating Instructions

Establishing Crimp Settings

The color coded collar and crimp adjustment knob above the pusher is designed to easily adjust to the Aeroquip and Weatherhead core products to determine the crimp diameter for each combination of hose, fitting, and die cage (See below). Simply turn the collar to the correct color to match the lay line on the hose, adjust the ring so that the correct size dot aligns with the correct size line on the collar and the machine is set for the correct crimp. Load the correct crimp die based on the crimp die chart attached to the machine, and the machine is ready to crimp.

The micrometer section can be used to crimp other products not captured on the 3 primary collar settings, based on crimp target settings available in PowerSource.

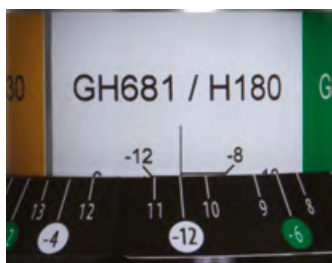

GH681 / H180

Standard machine comes with GH681/H180 settings built in for use with TTC/Z fittings in sizes -4 through -16.

-12 size setting shown



GH781 / H280

Standard machine comes with GH781/H280 settings built in for use with TTC/Z fittings in sizes -4 through -16.

-8 size setting shown

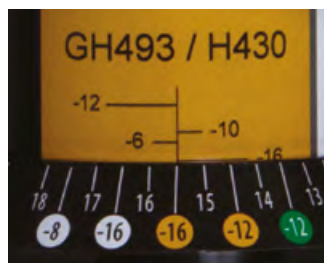

GH493 / H430

Standard machine comes with GH493/H430 settings built in for use with TTC12/4S fittings in sizes -6 through -10, and 4S fittings in sizes -12 and -16.

-16 size setting shown

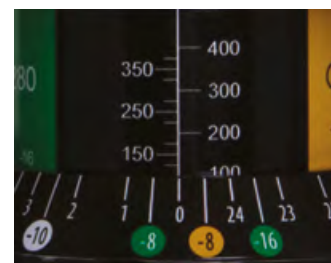

Micrometer Dial

The micrometer section can be used to crimp other products not captured on the 3 primary collar settings, based on crimp target settings available in PowerSource.

Crimp Procedures

(using FT1380-200-MXXX Series Die Cages)

Step 1



Figure 1

Reference the crimp specification chart on the front of the crimp machine to determine proper crimp dies for hose and fitting.

Step 2



Figure 2

Install FT1380-200-XXX Die Cage per crimp die chart on the front of the machine.

Step 3



Figure 3

Rotate hose product selection collar until desired product group is facing operator.
NOTE: Collar has detents at each position to help ensure proper alignment with corresponding product groups.

Crimp Procedures - Continued

Step 4



Figure 4
Rotate crimp adjustment ring until desired dash size is lined up with corresponding dash size on product selection collar.

Step 5



Figure 5
Insert the hose assembly up through the bottom of the base ring and die cage. Begin crimping by actuating the pump.

Step 6



Figure 6
Crimp cycle is complete when cylinder travel stops and the green indicator ring on the piston shows beneath the top plate. After completion, visually inspect the crimp and verify the correct crimp diameter and length.

Correct Crimp Settings Example

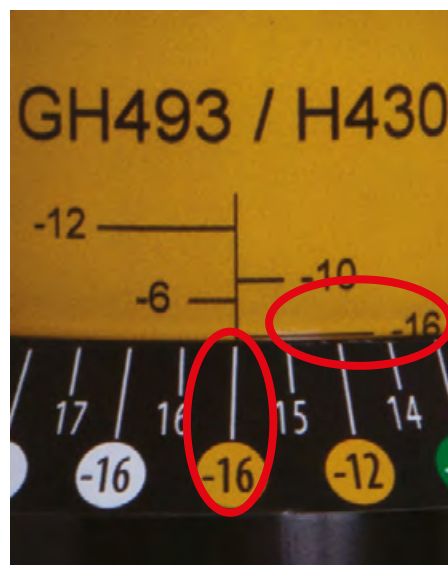

Figure 7
Crimp adjustment ring is in correct position for crimping -16, when vertical lines on the crimp adjustment ring and product selection collar are aligned, and -16 horizontal line on the collar is even with the top of the crimp adjustment ring.

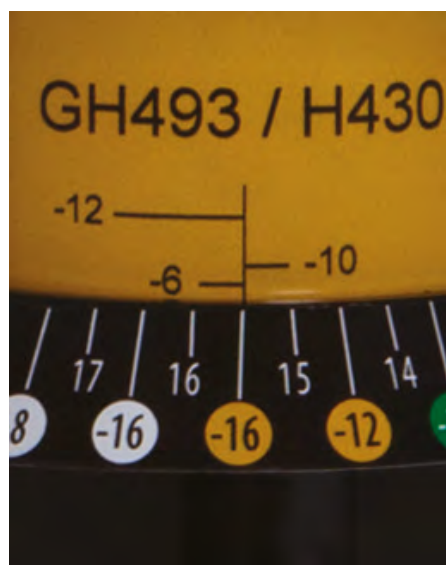

Figure 8
Crimp adjustment ring rotated one turn past correct position for -16 hose on the product selection collar.

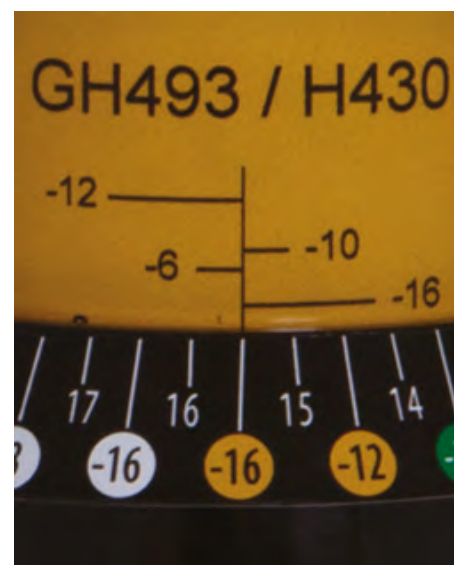

Figure 9
Crimp adjustment ring rotated one turn short of correct position for -16 hose on the product selection collar.

Establishing Crimp Settings - Micrometer Dial

The micrometer section on the color coded collar can be used to crimp other products not captured on the 3 primary color coded collar settings, based on crimp target settings available in PowerSource.

The crimp adjustment knob above the pusher determines the target crimp diameter for each combination of hose, fitting, and die cage.

The numbers on the color coded collar and crimp adjustment knob are for selecting target settings and not crimp diameters.

Settings between 000 and 400 can be achieved with this crimp machine.

Consult the target setting chart in PowerSource for the ET1187 crimp machine for the initial setting.

There are 25 marks on the crimp adjustment knob (0-24), and 16 marks on the barrel (025-400 by 025 increments)

When the crimp adjustment knob is rotated to where the knob is lined up with the 000 line on the collar, and the "0" mark on the knob is lined up as shown in figure 10. The crimper target setting is set at 000.

When the crimp adjustment knob is rotated to the top most position on the crimper, and the "0" mark is located as shown in Figure 11, the machine setting is 400.

Each complete upward rotation of the adjustment knob increases the target setting by 025; each mark around the dial corresponds to a 001 change in target setting.

For example, to achieve a target setting of 050, the adjustment knob is rotated until the top of it corresponds to the 050 mark on the collar, and the 0 mark on the dial is lined up with the center, vertical mark on the collar.

One more full upward rotation of the crimp adjustment knob would result in a target setting of 075. If the desired target setting is 065, the dial would instead be rotated upward 15 "marks" on the dial as shown in figure 12, or approximately 2/3 of a turn, past the 050 target setting.



Figure 10



Figure 11



Figure 22

Maintenance

Intervals

DIE CAGE LUBRICATION

Every 50 crimps	Relube sliding surfaces of dies
Every 500 crimps	Remove old grease and relube
Every 1000 crimps	Die cage maintenance

Crimp Ring Maintenance

Every 500 crimps	Remove old grease and relube
Every 2000 crimps	Remove old grease, inspect for wear or damage and relube if okay

NOTE: Use Accrolube lubricant (Danfoss part number T-400-G).

Procedures

MACHINE MAINTENANCE PROCURES

1. Sliding surfaces must be kept free of dirt and other abrasive materials.
2. All exposed zinc coated surfaces should be coated occasionally with a light film of oil to prevent corrosion.
3. Periodically check the oil level in the fluid reservoir of the hydraulic power unit. Maintain the oil level of pump manufacturer's hydraulic oil as needed.

NOTE: Completely retract the crimp ring when checking the oil level.

DIE CAGE MAINTENANCE PROCEDURES

1. Lubricate the die cage.
For maximum service. FT1380 die cages require lubrication at 50-crimp intervals with Accrolube (Danfoss part number T-400-G). Periodically remove Accrolube residue that has built-up on the sides of the dies and the crimp ring during the crimping process. Accrolube residue becomes contaminated with metal and plating chips and airborne contaminants, which can cause premature wear of the dies and crimp ring. It should carefully be removed without mixing it with newly applied Accrolube.
2. Die cage maintenance should be performed at 1000-crimp intervals or every six months, whichever occurs first. Die cages should be clean of grease and debris and inspected for worn or damaged components.
 - a. The sliding surface of the dies should appear smooth with no apparent galling. Galled dies must be replaced. Individual dies in a cage can be replaced without replacing all eight dies.
 - b. Replace springs that show any sign of damage or collapse (are shorter than other springs).
 - c. The spring plate should appear smooth with no apparent galling. Galled spring plates must be replaced.
 - d. Inspect remaining components and replace those that are badly worn.
3. Reassemble components and liberally apply Accrolube to the die surface which slides along the spring plate. Torque the die cage bolts to 50in.-lbs .
4. Ensure that all dies slide in and out freely.

Description of Components

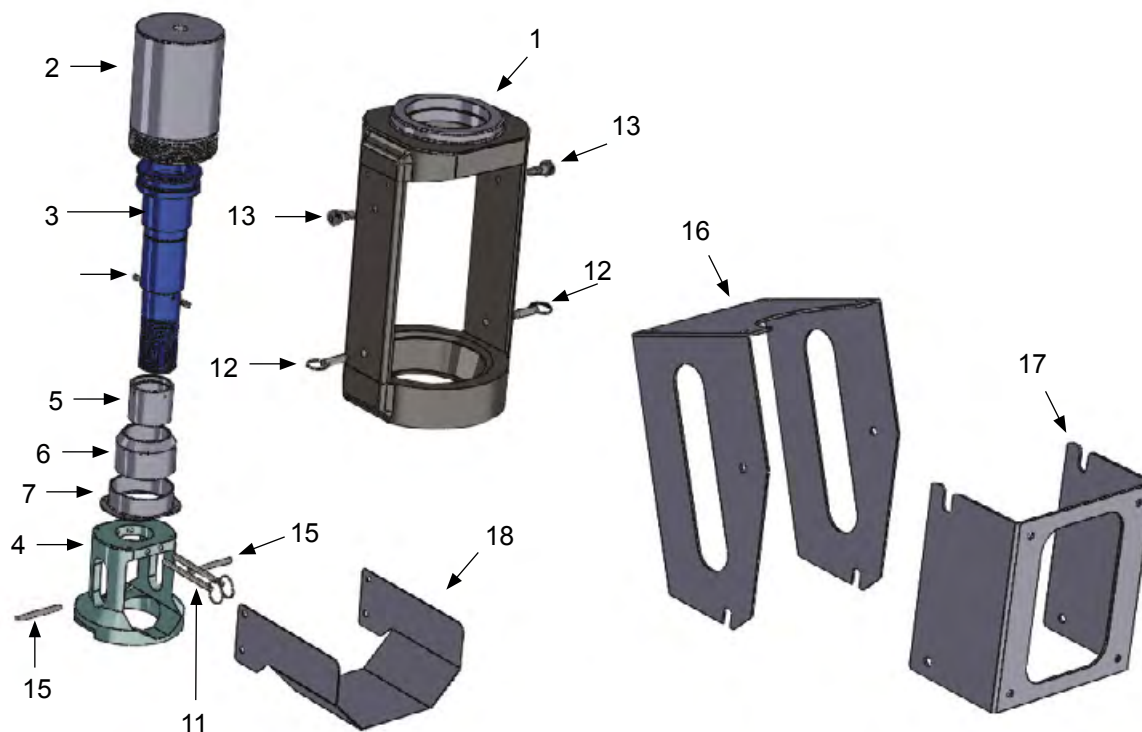

Detail	Part Number	Description	Qty
1	ET1187C-0007	CRIMP RING WELDMENT	1
2	ET1187C-0001	CYLINDER	1
3	ET1187C-0002	PISTON	1
4	ET1187C-0006	PUSHER CASTING	1
5	ET1187C-0008	BARREL	1
6	ET1187C-0009	ADJUSTABLE KNOB	1
7	ET1187C-0010	PINCH POINT HAT	1
8	140-05691	SEAL KIT - PISTON	1
9	ET1187C-0011	SPRING (Not Shown)	1
10	T-400-G	LUBRICANT (Not Shown)	1
11	ET1187C-0012	QUICK RELEASE PIN	2
12	ET1187C-0013	QUICK RELEASE PIN	2
13	ET1187C-0014	SHOULDER SCREW	2
14	ET1187C-0015	SPRING PLUNGER	2
15	ET1187C-0016	ROLL PIN	2
16	ET1187C-0017	BENCH MOUNT STAND	1
17	ET1187C-0018	WALL MOUNT BRACKET	1
18	ET1187C-0019	SHROUD	1

About Danfoss Power Solutions FC

Danfoss hoses, fittings, and tooling provide the ultimate fluid conveyance solutions for a variety of equipment and applications around the world. We proudly engineer to support a sustainable future for tomorrow.

To learn more please visit: <http://www.danfoss.com/en/about-danfoss/our-businesses/power-solutions>

Danfoss Power Solutions

14615 Lone Oak Road
Eden Prairie, MN 55344, USA
Phone: 952-937-9800

Danfoss Power Solutions (US) Company

2800 East 13th Street
Ames, IA 50010, USA
Phone: +1 515-239-6000

Danfoss Power Solutions GmbH & Co.OHG

Krokamp 35
D-2439 Neumünster, Germany
Phone: +49 4321 871 0

Danfoss Power Solutions ApS

Nordborgveg 81
DK-6430 Nordborg, Denmark
Phone: +45 7488 2222

Danfoss Power Solutions Trade (Shanghai) Co. Ltd.

Building #22, No 1000 Jin Hai Rd
Jin Qiao, Pudong New District
Shanghai, China 201206
Phone: +86 21 3418 5200w

Danfoss can accept no responsibility for possible errors in catalogs, brochures, and other printed material. Danfoss reserves the right to alter its products without notice. This also applies to products already on order provided that such alterations can be made without subsequent changes being necessary in specifications already agreed. All trademarks in this material are the property of the respective companies. Danfoss and the Danfoss logotype are trademarks of Danfoss A/S. All rights reserved.
