

DIMENSIONS ARE IN INCHES

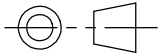

TOLERANCES (EXCEPT AS NOTED):  
 LINEAR DIM., 1 DEC. PLACES:  $\pm 0.03$   
 LINEAR DIM., 2 DEC. PLACES:  $\pm 0.01$   
 LINEAR DIM., 3 DEC. PLACES:  $\pm 0.005$   
 FRACTIONS & WHOLE NUMBERS:  $\pm 1/32$ "  
 CASTINGS:  $\pm 1/16$ "  
 CONCENTRICITY: 0.005 MAX  
 ANGLES:  $\pm 30'$   
 MACHINE FINISH (MICRO-INCH): 125  
 REMOVE SHARP EDGES AND BURRS

NOTES:

1. ALL HOLES TO BE ADDED WHERE SPECIFIED.

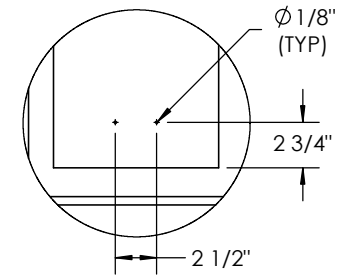
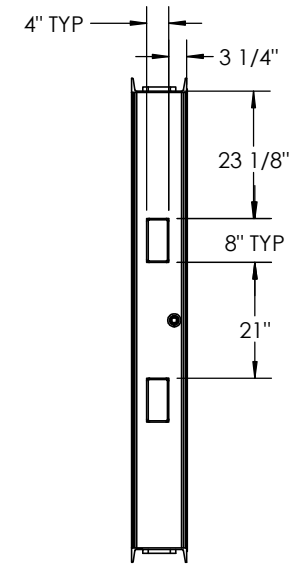
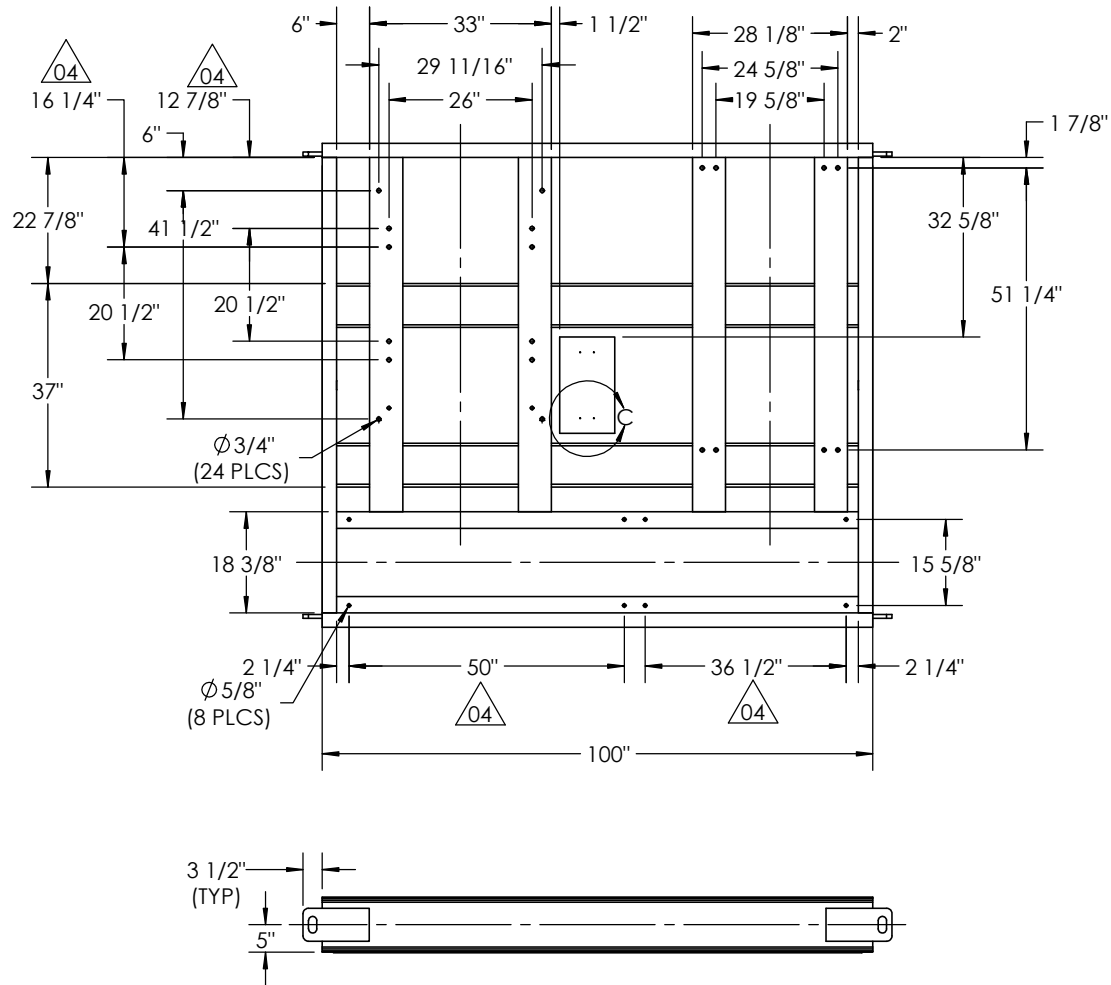

DETAIL C  
SCALE 1 : 8

DIMENSIONS ARE IN INCHES

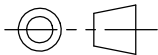

TOLERANCES (EXCEPT AS NOTED):  
 LINEAR DIM., 1 DEC. PLACES:  $\pm 0.03$   
 LINEAR DIM., 2 DEC. PLACES:  $\pm 0.01$   
 LINEAR DIM., 3 DEC. PLACES:  $\pm 0.005$   
 FRACTIONS & WHOLE NUMBERS:  $\pm 1/32$ "  
 CASTINGS:  $\pm 1/16$ "  
 CONCENTRICITY: 0.005 MAX  
 ANGLES:  $\pm 30$ "  
 MACHINE FINISH (MICRO-INCH): 125  
 REMOVE SHARP EDGES AND BURRS

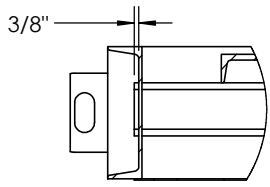

DETAIL D  
SCALE 1 : 10

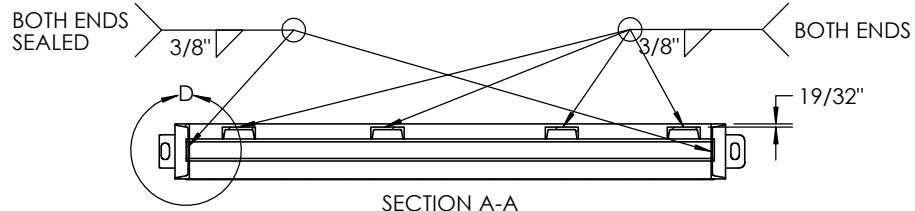

SECTION A-A

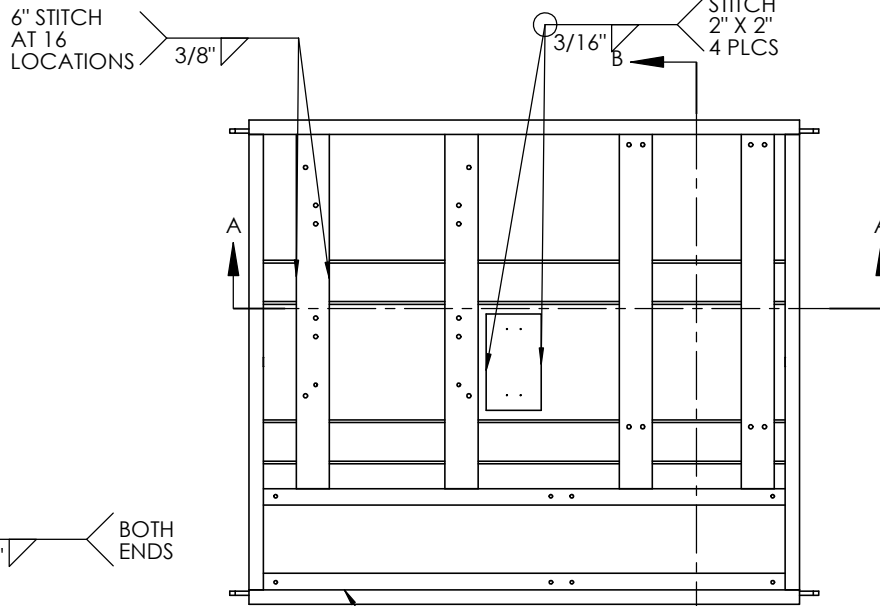

6" STITCH  
AT 16  
LOCATIONS

STITCH  
2" X 2"  
4 PLCS

BOTH  
ENDS

STICH 3" ON  
EVERY 12"

SECTION B-B

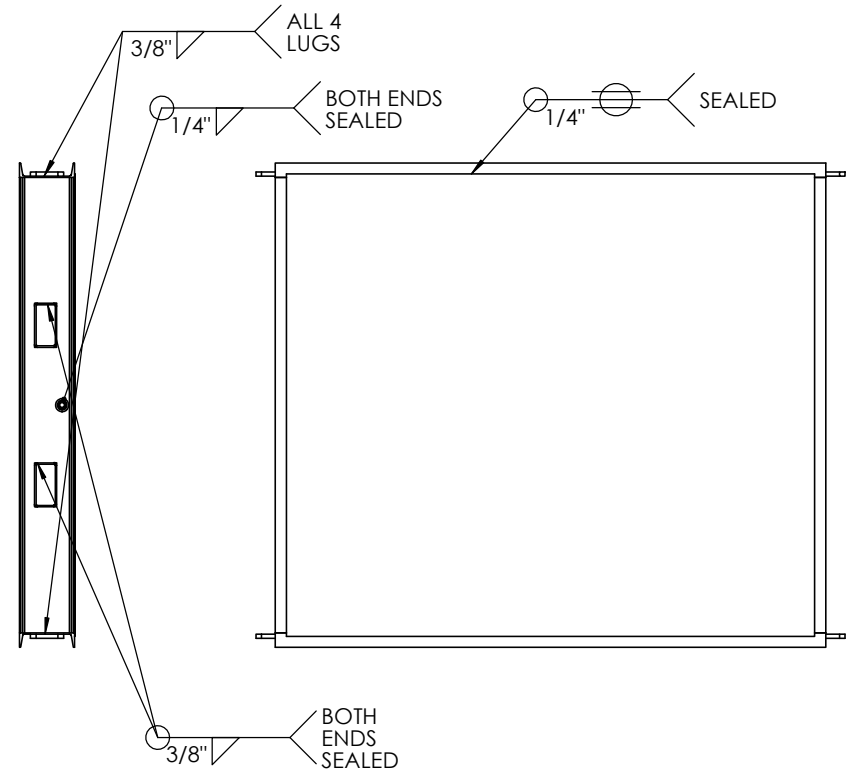

ALL 4  
LUGS

BOTH ENDS  
SEALED

SEALED

BOTH  
ENDS  
SEALED



ALL 4  
LUGS

DIMENSIONS ARE IN INCHES

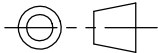

TOLERANCES (EXCEPT AS NOTED):  
 LINEAR DIM., 1 DEC. PLACES: ± 0.03  
 LINEAR DIM., 2 DEC. PLACES: ± 0.01  
 LINEAR DIM., 3 DEC. PLACES: ± 0.005  
 FRACTIONS & WHOLE NUMBERS: ± 1/32"  
 CASTINGS: ± 1/16"  
 CONCENTRICITY: 0.005 MAX  
 ANGLES: ± 30"  
 MACHINE FINISH (MICRO-INCH): 125  
 REMOVE SHARP EDGES AND BURRS